

SERVICE BULLETIN NO. 182 R1

E-60 & E-60H

MOTOR REPLACEMENT

Under Meyer Products continuing Products Improvement Program, the E-60 and E-60H electric motor part number 15689 (12V) and 15767 (24) Single Terminal, used in production and for service replacement will no longer be available. A new two terminal motor with separate terminals for (+) positive and (-) negative cable connections is now available.

Service replacement of the single terminal motors require a new motor mounting plate be installed due to the drain hole location on the new two terminal motor, an extra ground cable to be attach to the D1 (-) terminal on the electric motor. This ground cable should be attached along with the standard ground cable to the grounding stud on the hydraulic unit then to the D1(-) terminal on the electric motor, per illustration.

Please note that replacement of an existing two terminal motor on a hydraulic unit that has the motor mounting plate with the tabs requires the motor only, part number 15727.

15689 Motor				15767 Motor			
Item	Part No.	Qty.	Description	Item	Part No.	Qty.	Description
	15841	1	Replacement Kit (12V)		15894	1	Replacement Kit (24V)
1	15727	1	• Motor - Two Terminal 12V	1	15891	1	• Motor - Two Terminal 24V
2	15892	1	• Motor Mounting Plate w/tabs	2	15892	1	• Motor Mounting Plate w/ tabs
3	21929	2	•• Washer, Nyltite 5/16	3	21929	2	•• Washer, Nyltite 5/16
4	15687	1	•• O-Ring 4-3/4" I.D.	4	15687	1	•• O-Ring 4-3/4" I.D.
5	15686	1	•• Seal, Pump Shaft	5	15686	1	•• Seal, Pump Shaft
6	15842	1	• Ground Cable	6	15842	1	• Ground Cable

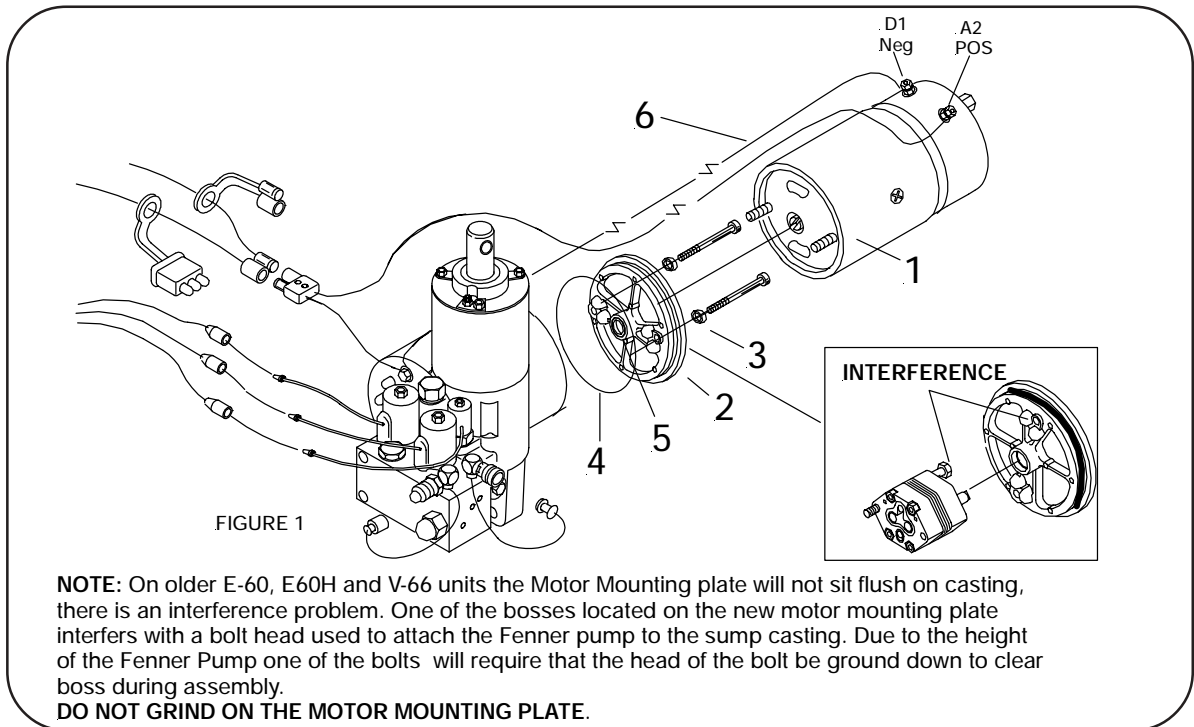

Meyer Products assumes no responsibility for installations not made in accordance to these instructions.

Meyer Products and Diamond Equipment reserves the right, under its continuing product improvement program, to change construction or design details, specifications and prices without notice or without incurring any obligation.

18513 Euclid Ave. • Cleveland, Ohio 44112-1084
 Phone 486-1313 (Area Code 216)
 email • warranty@meyerproducts.com



Diamond Equipment
 6 Angell Lane • Damariscotta, ME 04543-9720
 Phone 563-2227 (Area Code 207)
 www.diamondplow.com • email info@diamondplow.com