

SERVICE BULLETIN No. 157

E-60 and E-60H Quik-LiftTM Units SEAL REPLACEMENT (Part # 15686)

Under Meyer Products continuing Product Improvement Program, a new Pump Shaft Seal is now available. The part number for the Shaft Seal has not changed.

Units manufactured after December 22, 1993 have been updated and will incorporate the new seal.

Installation Instructions: Reference Form 1-663R

Disassembly

- A. Remove Motor End Cover and then remove Motor from unit.
- B. Remove Motor Mounting Plate bolts. Discard the Nyltite washers.
- C. Remove Motor Mounting Plate.
- D. Remove old style (black) Pump Shaft Seal from Mounting Plate.
- E. Remove and discard Pump Shaft Bushing (Part #15739) from Pump Shaft.

Assembly

- F. Assemble new (green) Pump Shaft Seal (Part #15686) into the Motor Mounting Plate.

Caution: Care should be taken not to distort seal during assembly.
When Seal is bottomed out in casting, seal will extend past casting approximately 1/16th of an inch.

- G. Reassemble Motor Mounting Plate using new Nyltite washers on Mounting bolts. Torque bolts to 96-120 inch Pounds.

IMPORTANT: Check Pump shaft rotation for binding prior to and after the assembly of the Motor Mounting Plate

- H. Reassemble Motor and Motor end Cover. Torque Motor bolts to 60-70 inch pounds
- I. Refill unit with M-1 oil. **Note:** If original oil from unit is not contaminated it may be reused.
- J. Test unit for oil leaks and proper operation.

Seal Failure Due To Improper Installation Will Not Be Covered Under The Meyer Warranty Program.

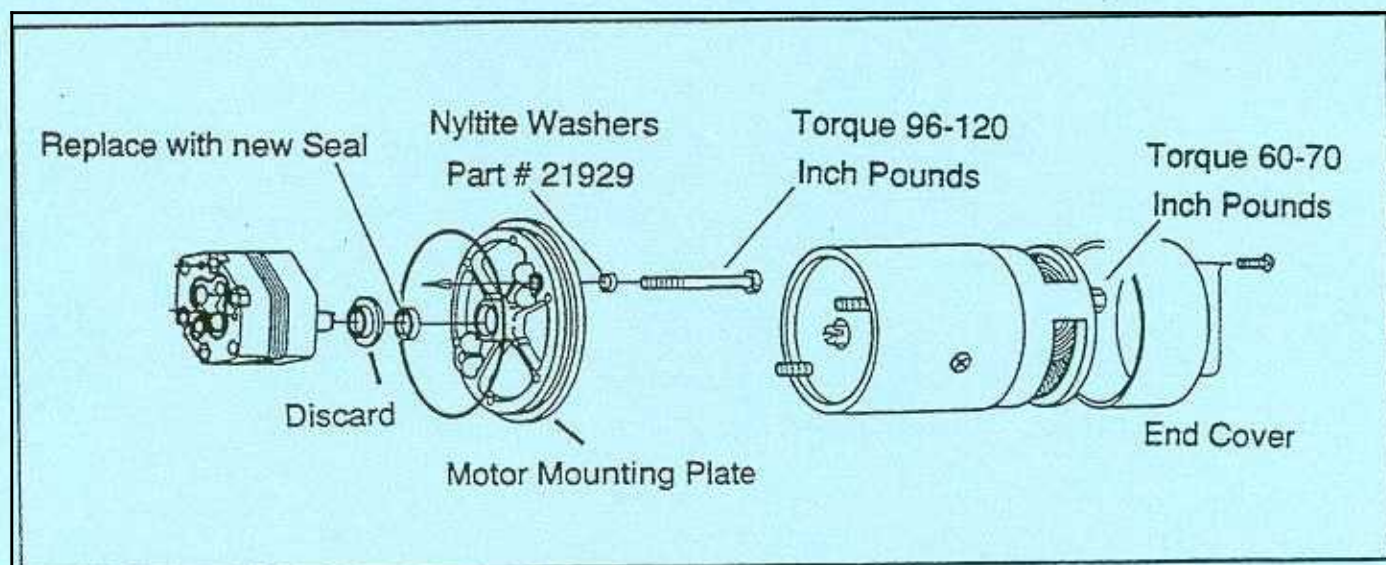

Meyer Products assumes no responsibility for installations not made in accordance with these instructions.